

User's Guide

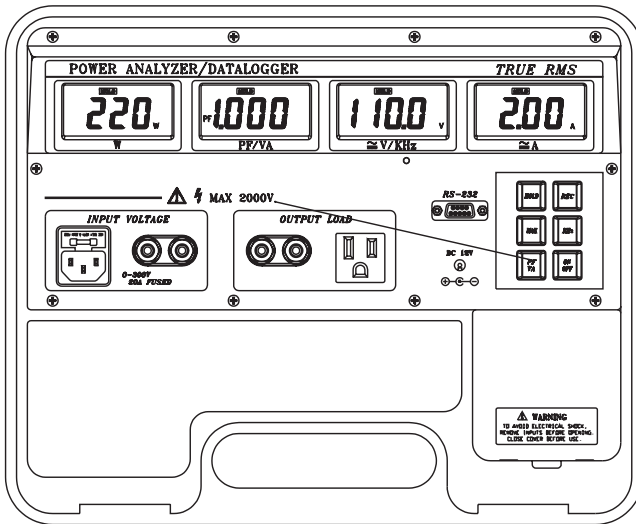

Power Analyzer Model 380801

Power Analyzer Datalogger Model 380803



Introduction

Congratulations on your purchase of the Extech 380801 or 380803 Power Analyzer Datalogger. This device offers the following features:

- Convenient front panel plug-in and testing
- Four displays for Watts, PF/VA, V/KHz, Amperes
- True power, true RMS for AC Voltage (V) and Current (A)
- Datalogger stores over 1000 readings (Model 380803)
- Auto Range for Watts and Volts
- RS-232 PC Interface
- Windows™ Application Software

Careful use of this meter will provide years of reliable service.

Warranty

EXTECH INSTRUMENTS CORPORATION warrants this instrument to be free of defects in parts and workmanship for one year from date of shipment (a six month limited warranty applies on sensors and cables). If it should become necessary to return the instrument for service during or beyond the warranty period, contact the Customer Service Department at (781) 890-7440 ext. 210 for authorization or visit our website at www.extech.com (click on 'Contact Extech' and go to 'Service Department' to request an RA number). A Return Authorization (RA) number must be issued before any product is returned to Extech. The sender is responsible for shipping charges, freight, insurance and proper packaging to prevent damage in transit. This warranty does not apply to defects resulting from action of the user such as misuse, improper wiring, operation outside of specification, improper maintenance or repair, or unauthorized modification. Extech specifically disclaims any implied warranties or merchantability or fitness for a specific purpose and will not be liable for any direct, indirect, incidental or consequential damages. Extech's total liability is limited to repair or replacement of the product. The warranty set forth above is inclusive and no other warranty, whether written or oral, is expressed or implied.

Specifications

WATT (Auto Range, AC+DC, Crest Factor < 5)

Range	Resolution	Accuracy	Input
200W	0.1W	$\pm(0.9\% \text{ reading} + 5 \text{ digits})$ (50/60Hz)	0-300V, 0-20A, PF=0.5 to 1
2000W	1W	$\pm(5\% \text{ reading} + 9 \text{ digits})$ (40 to 400Hz)	

VOLTAGE (True RMS, Auto Range, AC+DC, Crest Factor < 5)

Range	Resolution	Accuracy	Overload Protection
200V	0.1V	$\pm(0.5\% \text{ reading} + 5 \text{ digits})$ (40 to 400Hz)	1000VDC/750VAC
750V	1V		

CURRENT (True RMS, AC+DC, Crest Factor < 5)

Range	Resolution	Accuracy (40 to 400Hz)	Overload Protection
2	0.001A	$\pm(0.5\% \text{ reading} + 5 \text{ digits})$	20A, fused
20	0.01A		

PF (Direct Calculation from W, V, A): $PF = \text{Watt} / (V * A)$

FREQUENCY (Sensitivity 5V)

Range	Resolution	Accuracy
40Hz to 20kHz	1Hz-10Hz	$\pm(0.5\% \text{ of rdg} \pm 2 \text{ digits})$

Memory Size (380803)	1012 x 4 readings (non-volatile)
Memory Life (380803)	100,000 memory writes
Display	2000 count LCD displays
Over Range Indication	'OL' displayed on LCD
Sampling Rate	2.5 times per second
Power Source	Eight 1.5V 'AA' batteries or AC adaptor
Power Consumption	22 mA approx.
Operating conditions	32 to 122°F (0 to 40°C); Less than 80%
Dimension	13.9"(L) x 11.8"(W) x 3.9" (H) 352(L) x 300(W) x 100(H)mm
Weight	3.6 lbs (1.637 Kg) approx.

Meter Description

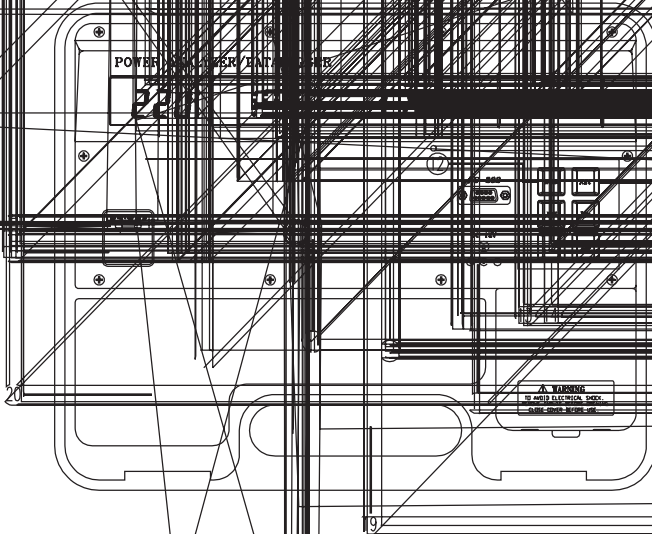

1. Watts display
2. PF or VA display
3. V or KHz display
4. A display
5. 20A fuse
6. Input Receptacle
7. Input Terminal
8. Output Terminal
9. Output Receptacle
10. RS-232 Terminal
11. DC 12V Adaptor Input
12. Hold
13. MAX button
14. PF/VA Select Button
15. REC button (380803)
16. KHz (frequency)
17. On/Off Button
18. Battery Compartment Cover
19. Carrying Handle
20. Storage Space for Accessories.

Basic Operation

Warning: If a power source of 220V is connected to the input voltage terminal/receptacle, do not connect a 110V device to the output load terminal/receptacle.

Using Receptacles

1. Plug one end of the power cord into the input receptacle and plug the other end into the wall outlet.
2. Plug the device to be tested into the output load receptacle. The display will show the W, PF, V, and A for the device under test.

Note 2: $W = VA$, $1KW = 1KVA = 1000W = 1000VA$, when $PF = 1$.

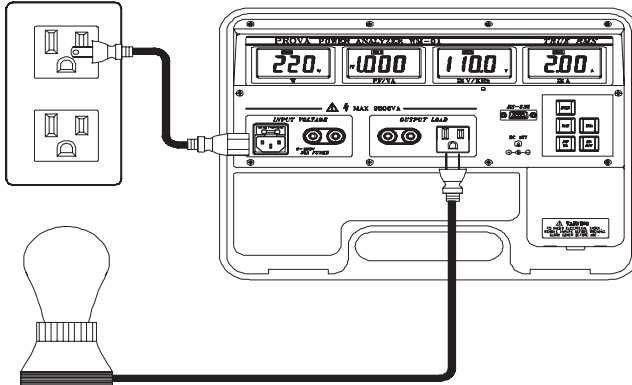

Warning: The input receptacle and terminal are connected in parallel (as are the outputs). To avoid electrical shock, do not touch any metal part of the receptacle or terminal.

Using Terminals

1. Plug one end of the power leads into the input voltage terminal (left) and connect the other end of the test leads to the power source.
2. Plug the device power leads into the output load terminals. W, PF, V, and A will display for the device under test.

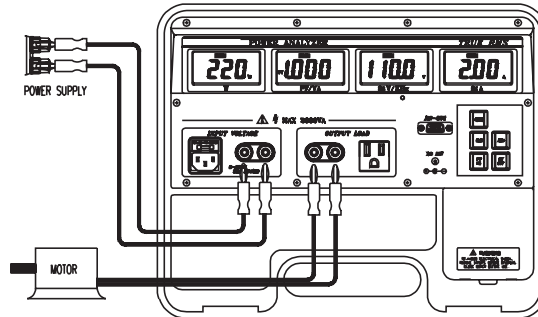

Note 2: $W = VA$, $1KW = 1KVA = 1000W = 1000VA$, when $PF = 1$ at DC

Warning: The input and output receptacle and terminal are connected in parallel. Do not touch any metal part of the receptacle or terminal to avoid electrical shock.

Using a Current Transformer

Warning: Only personnel well trained in the principles of Current Transformers (CT) should attempt this test connection. When connecting a CT, follow the wiring diagrams and instructions below.

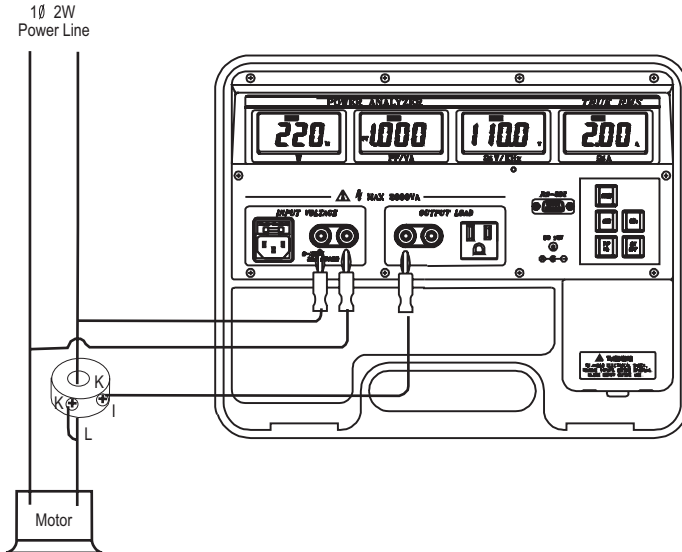

1. Connect the CT's *k* terminal (entering the CT) to the power line that passes through the CT, and connect this *k* terminal to the **input voltage black terminal** (ground).
2. Connect the other power line to the input voltage red terminal.
3. Connect the CT's *I* terminal (leaving the CT) to the output load black terminal (ground).
4. The Watt reading and Amp reading should be multiplied by the CT ratio. The V and PF readings do not need to be multiplied by the CT ratio.

Warning: The input receptacles and terminals are connected in parallel (as are the outputs). Do not touch any metal part of the receptacle or terminal.

PC Interface for Data Acquisition & Datalogging Features

Data Acquisition

Models 380801 and 380803 can be connected to a PC where readings can be logged in real-time as they are taken. Transferred reading data can be viewed, plotted, statistically analyzed, printed, saved, and imported in spreadsheet, database, word processing, and other software programs. Instructions for Data Acquisition are included in the separate Data Acquisition and Datalogging Manual on the software disc.

Datalogging (Model 380803 only)

The Model 380803 has built-in memory where over one thousand readings can be stored for later transfer to PC. Once transferred, data can be viewed, plotted, statistically analyzed, printed, saved as a text file, and imported in spreadsheet, database, word processing, and other software programs. Instructions for Datalogging are included in the separate Data Acquisition and Datalogging Manual.

Replacement of Batteries and 20A Fuse

Battery Replacement

When the low battery symbol is displayed on any of the LCDs, replace the eight (8) 1.5V 'AA' batteries.

1. Turn off the power analyzer.
2. Open the battery compartment by using a screw driver (see diagram).
3. Replace the batteries.
4. Replace the battery compartment.

20A Fuse Replacement

To replace the 20A fuse, remove the fuse cover as indicated in item (5) in the Meter Description section earlier in this manual and replace the fuse if necessary.

Warning: Do not replace the blown fuse with a fuse rating greater than 20A.
--

Measurement of 3-Phase 3-Wire Power

Using One Power Analyzer

Measure W_{RS} first (RST phases must be correctly identified)

1. Connect the R-phase of the power source to the black terminal of the input voltage
2. Connect the S-phase of the power source to the red terminal of the input voltage
3. Plug the R-phase of the device to be tested to the black terminal of the output load. Do not short the R-phase of the device to be tested to the R-phase of the input power source.
4. Record the reading of W_{RS} displayed on the 'W' LCD.

Measure W_{TS} secondly (RST phases must be correctly identified)
Connect the R-phase of the power source to the black terminal of the input voltage

- 2.
3. Do not short the R-phase of the device to be tested to the R-phase of the input power source.

Using Two Power Analyzers

Measure W_{RS} and W_{TS} (RST phases must be correctly identified)

1. Connect the R-phase of the power source to the black terminal of the input voltage of power analyzer 1.
2. Connect the S-phase of the power source to the red terminal of the input voltage of power analyzer 1.
3. Plug the R-phase of the device to be tested to the black terminal of the output load of power analyzer 1. Do not short the R-phase of the load to the R-phase of the input power source.
4. Record the reading of W_{RS} displayed on the 'W' LCD of power analyzer 1.
5. Connect the T-phase of the power source to the black terminal of the input voltage of power analyzer 2.
6. Connect the S-phase of the power source to the red terminal of the input voltage of power analyzer 2.
7. Plug the T-phase of the device to be tested to the black terminal of the output load of power analyzer 2. Do not short the T-phase of the device to be tested to the T-phase of the input power source.
8. Record the reading of W_{TS} displayed on the Watt LCD of power analyzer 2.

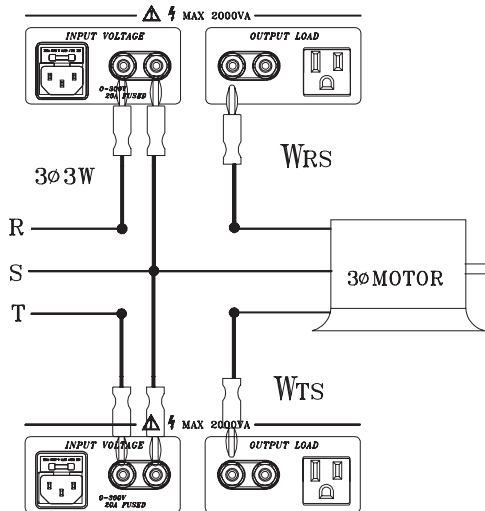

Using Current Transformers (CT) with 2 Power Analyzers

Measure W_{RS} and W_{TS} (RST phases must be correctly identified)

1. Connect the R-Phase to the black terminal of the input voltage of power analyzer 1.
2. Connect the S-phase to the red terminal of the input voltage of power analyzer 1.
3. Connect the k terminal of CT1 to the R-phase.
4. Connect the l terminal of CT1 to the black terminal of the output load of power analyzer 1.
5. The Watt reading of the power analyzer 1 is W_{RS}
6. Connect the T-phase to the black terminal of the input voltage of power analyzer 2.
7. Connect the S-phase to the red terminal of the input voltage of power analyzer 2.
8. Connect the k terminal of CT2 to the R-phase.
9. Connect the l terminal of CT2 with the black terminal of the output load of power analyzer 1.
10. The Watt reading of the power analyzer 2 is W_{TS}

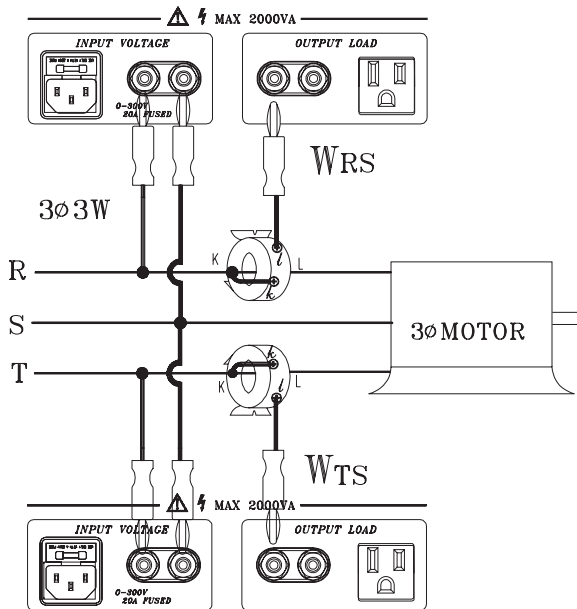

Glossary of Terms

W	True Watt
PF	Power Factor
V	True RMS Voltage
A	True RMS Ampere
Phase angle	Time difference between V and A calculated by \cos^{-1} (Power Factor)
VA	Apparent Power ($V * A$)
VAR	Reactive Power ($\text{SQRT}[VA^2 - W^2]$)
IR	Equivalent current (through equivalent resistance)
Req	Equivalent resistance
IL	Equivalent current (through equivalent inductance)
XL	Equivalent impedance of equivalent inductance
Leq	Equivalent inductance
CAP	Required capacitance
CR	Carriage Return
LF	Line Feed
EPS	Datalogger Memory Self-test
EPE	Erasing Datalogger Memory
$W_{3\phi}$	True Power (3ϕ 3W)
W_{RS}	Power of R phase with respect to S phase
W_{TS}	Power of T phase with respect to S phase
$VA_{3\phi}$	Apparent Power (3ϕ 3W and Balanced Load)
$VAR_{3\phi}$	Reactive Power (3ϕ 3W and Balanced Load)
$PF_{3\phi}$	Power Factor (3ϕ 3W and Balanced Load)
Mean	Mean Value
Std Dev	Standard Deviation
Best Fit	A line drawn to fit a curve with minimum error

Calibration and Repair Services

Extech offers complete repair and calibration services for all of the products we sell. For periodic calibration, NIST certification on most products or repair of any Extech product, call customer service for details on services available. Extech recommends that calibration be performed on an annual basis to ensure calibration integrity.



Support line (781) 890-7440

Technical support: Extension 200; E-mail: support@extech.com

Repair & Returns: Extension 210; E-mail: repair@extech.com

Product specifications subject to change without notice

For the latest version of this User's Guide, Software updates, and other up-to-the-minute product information, visit our website: www.extech.com
Extech Instruments Corporation, 285 Bear Hill Rd., Waltham, MA 02451

Copyright © 2006 Extech Instruments Corporation.
All rights reserved including the right of reproduction in whole or in part in any form.

airconcern

more info for Extech 380801

Phone: 01235 838 555

Email: cs@airconcern.co.uk

Web: www.airconcern.co.uk

Air Concern Ltd, Building 173 Curie Avenue Harvell Didcot, Oxfordshire